

ELEVACION A

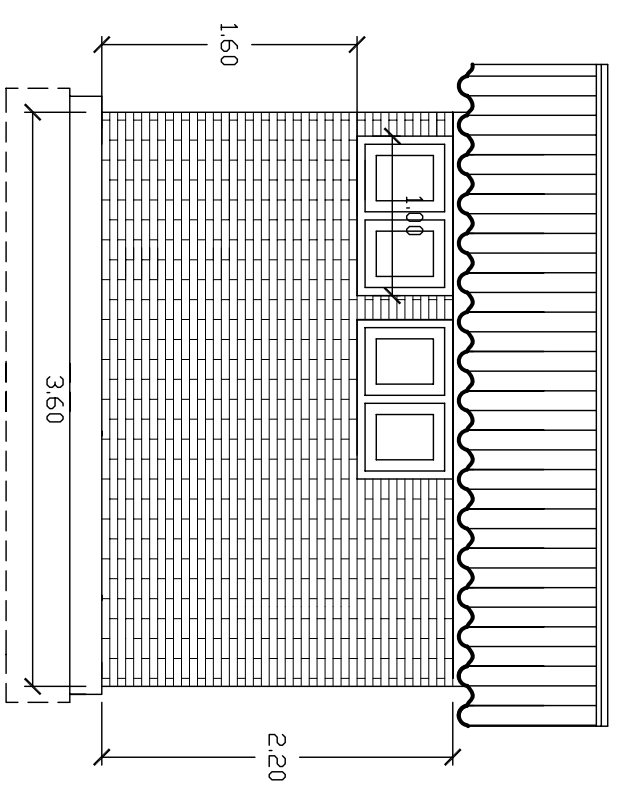

ELEVACION B

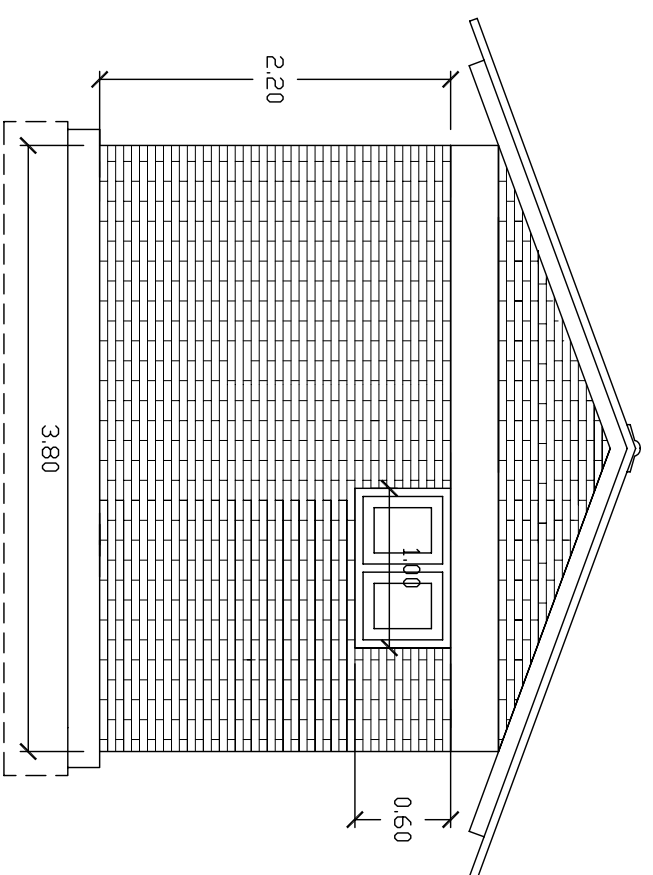

ELEVACION C

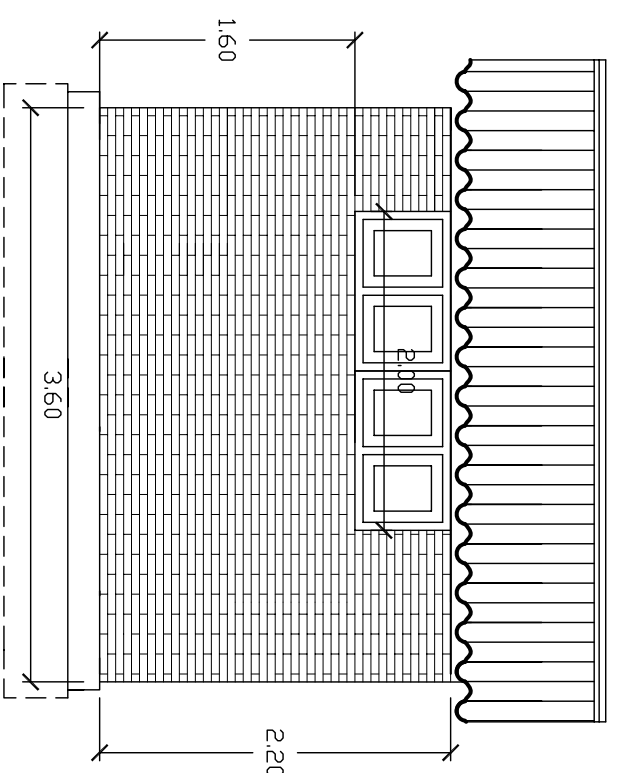

ELEVACION B

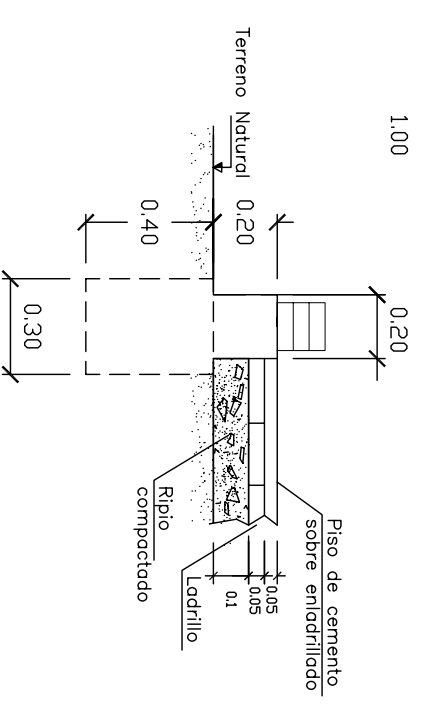

DETALLE DE PISO

REV.	FECHA	DESCRIPCION	POR	APROBO
		EMPRESA NACIONAL DE ELECTRICIDAD S. A.		
INGENIERIA Y FISCALIZACION				
LINEA CARANAVI-TRINIDAD				
OBRAS CIVILES				
BAÑOS SAN BORJA				

PROYECTADO POR: Ing. F. Ramirez E.	PRIMA	ESCALA:
REVISADO POR:		FECHA: ABR/09
DIBUJADO POR: Rosa Martinez C.		CODIGO: LCT-GP-L-C-XX
APROBADO GERENTE PROYECTO Ing. Ramiro Mendezal		